



### Power Rectifier Diodes

#### Applications

- Traction Rectifiers
- Uncontrolled Rectifiers
- Welding
- Induction Heating / Melting

#### Features

- Full blocking capability over wide temperature range
- Hermetically sealed ceramic package
- High case non-rupture current

#### Key Parameters

$V_{RRM}$	= 3000V
$I_{F(AV)}$	= 2700A
$I_{FSM}$	= 32000A
$V_{F(TO)}$	= 0.87V
$r_F$	= 0.127mΩ

Symbol	Characteristic	Conditions	$T_j$ [°C]	Value	Unit
<b>BLOCKING</b>					
$V_{RRM}$	Repetitive peak reverse voltage		175	2400 - 3000	V
$V_{RSM}$	Non-repetitive peak reverse voltage		175	2500 - 3100	V
$I_{RRM}$	Repetitive peak reverse current	$V = V_{RRM}$	175	75	mA
<b>CONDUCTING</b>					
$I_{F(AV)}$	Mean forward current	180° sin, 50 Hz, $T_c=82^\circ\text{C}$ , double side cooled 180° sin, 50 Hz, $T_c=85^\circ\text{C}$ , double side cooled		2700 2650	A
$I_{FRMS}$	RMS current			4239	A
$I_{FSM}$	Surge forward current	Sine wave, 10 ms Without reverse voltage	25	32000	A
			175	30500	A
$I^2 t$	$I^2 t$	Sine wave, 10 ms Without reverse voltage	25	$5120 \times 10^3$	A <sup>2</sup> s
			175	$4651 \times 10^3$	A <sup>2</sup> s
$V_F$	Forward voltage	On-state current = 2900A	25	1.30	V
$V_{F(TO)}$	Threshold voltage		175	0.87	V
$r_F$	Forward slope resistance		175	0.127	mΩ
<b>MOUNTING</b>					
$R_{th(j-c)}$	Thermal impedance, DC	Junction to case, double side cooled		0.020	°C/W
$R_{th(c-h)}$	Thermal impedance	Case to heatsink, double side cooled		0.006	°C/W
$T_j$	Max. junction temperature			175	°C
$T_{stg}$	Storage temperature			-40 ... 175	°C
M	Clamping force			18 - 20	KN
W	Weight (Approx.)			550	gm

**DISSIPATION CHARACTERISTICS**

SINE WAVE

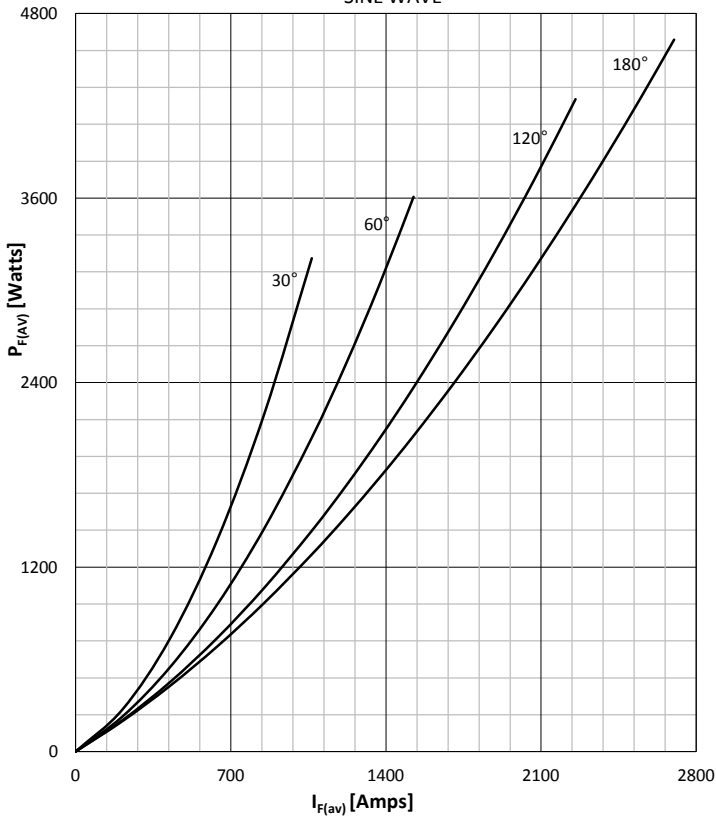
**FORWARD CURRENT DERATING CURVE**

SINE WAVE

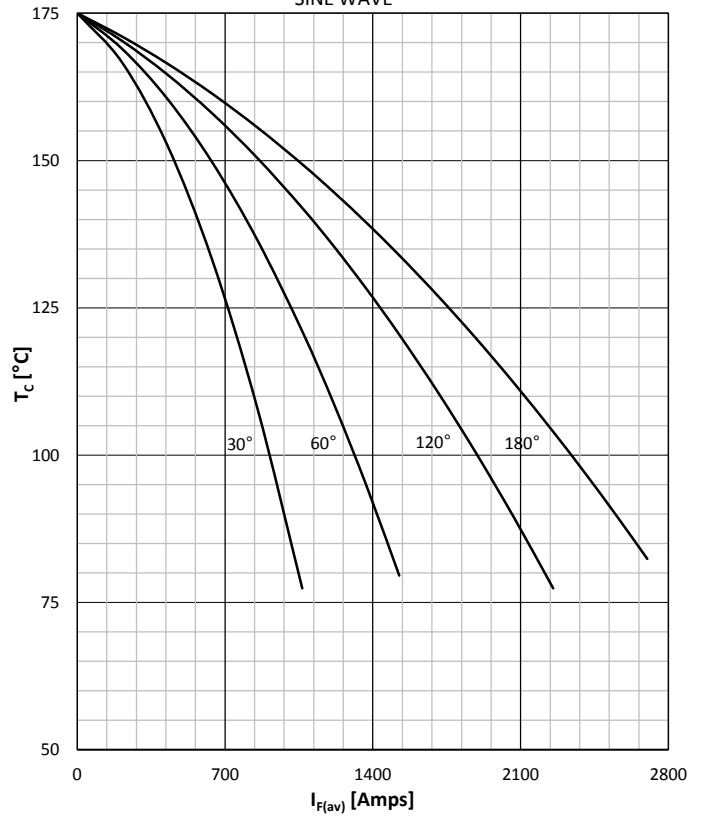
**DISSIPATION CHARACTERISTICS**

SQUARE WAVE

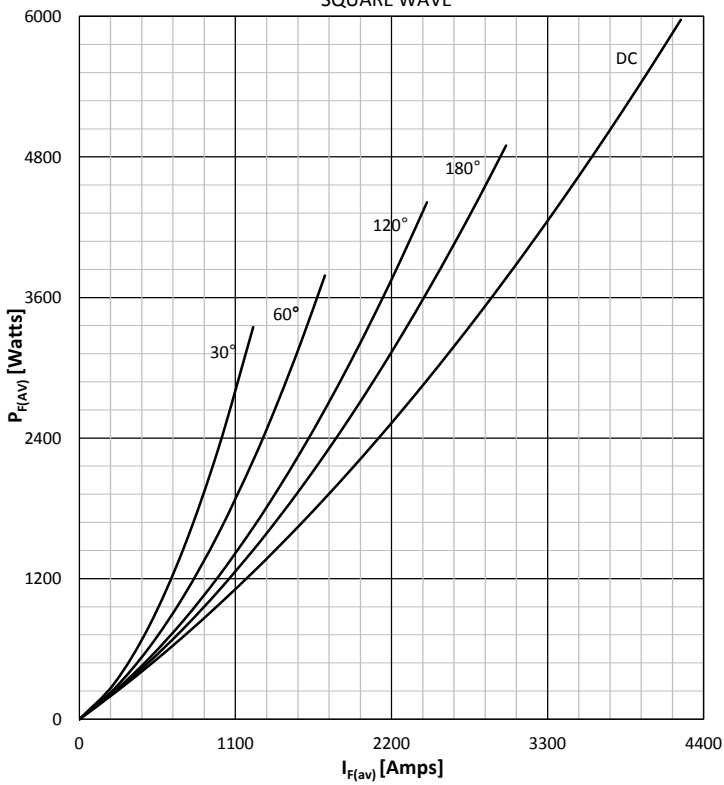
**FORWARD CURRENT DERATING CURVE**

SQUARE WAVE

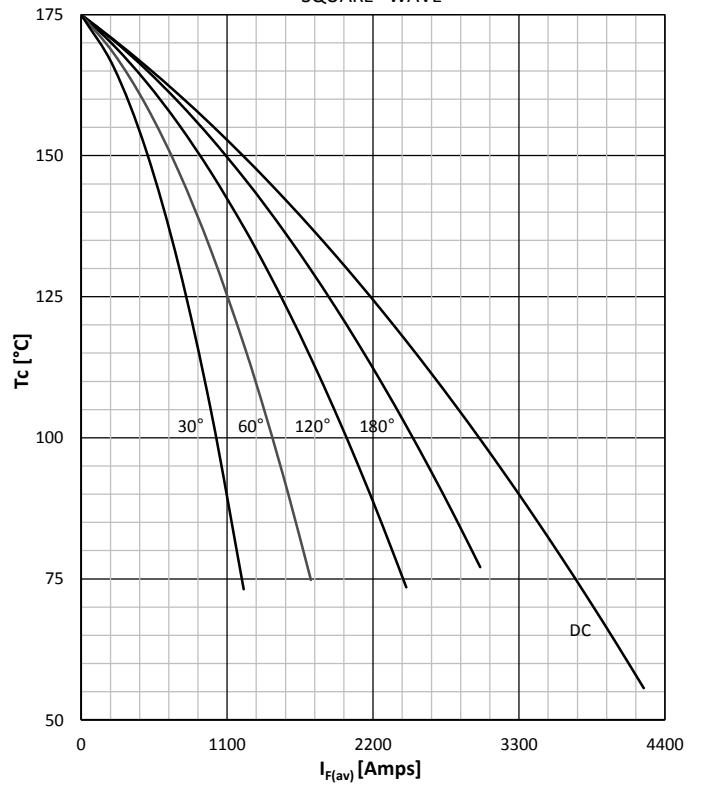

**FORWARD CHARACTERISTIC**

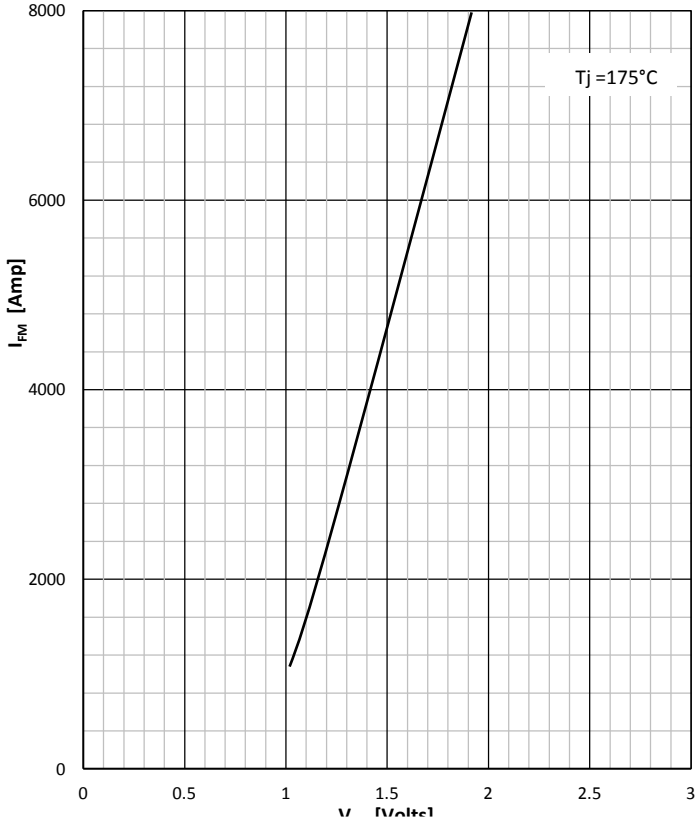

**SURGE CHARACTERISTICS**

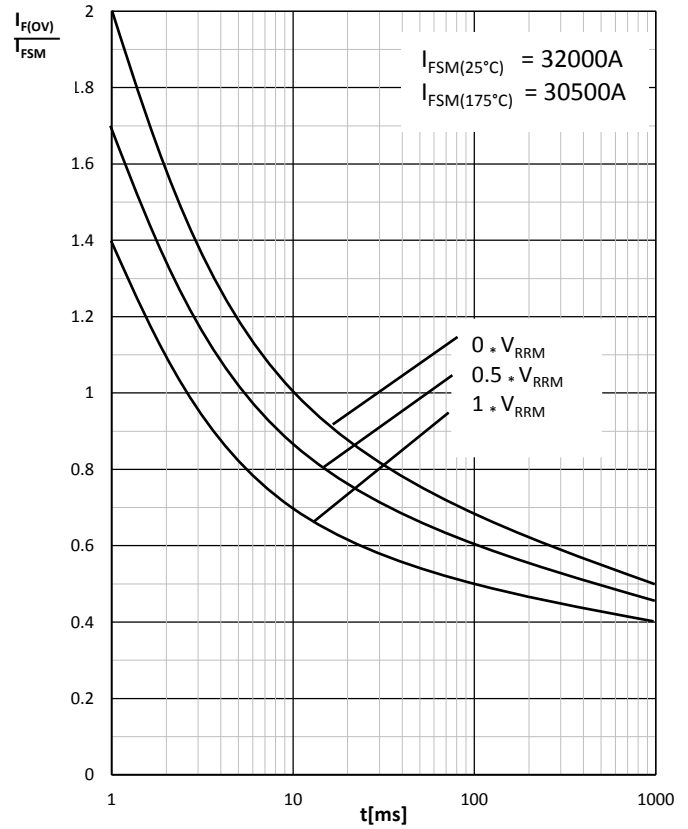

**TRANSIENT THERMAL IMPEDANCE, DSC**

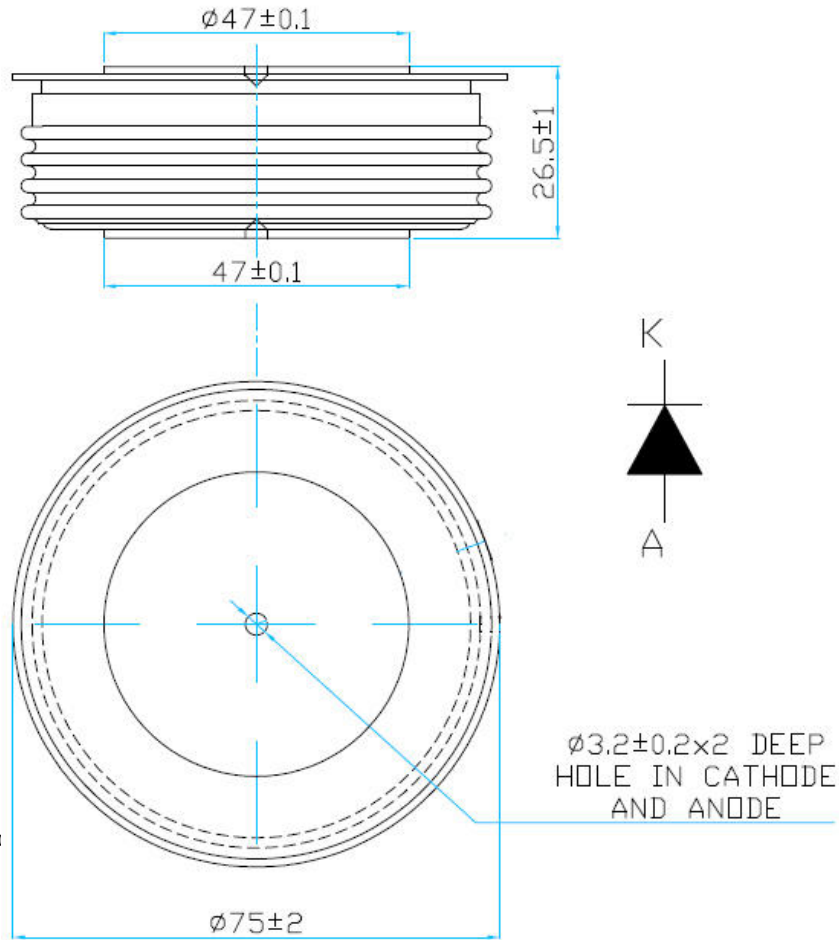
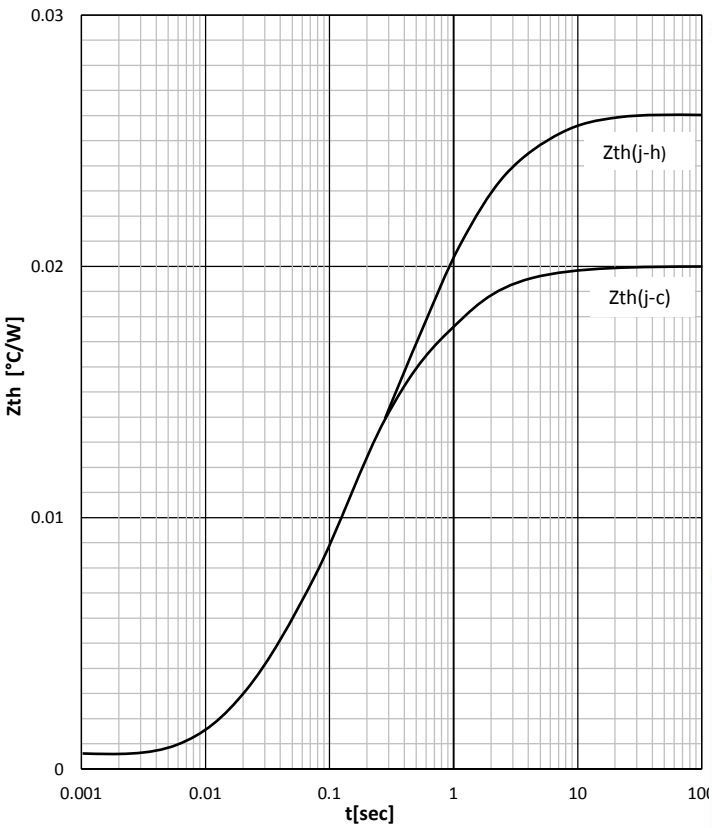

*Scomes srl reserves the right to change any specification without notice*

*issue.mar-2019*