



## SCT1155

### Power Rectifier Thyristor

#### Key Parameters

$V_{DRM} / V_{RRM}$	= 600V
$I_{T(AV)}$	= 1155A
$I_{TSM}$	= 16.0kA
$V_{T(TO)}$	= 0.85V
$r_T$	= 0.25mΩ

#### Features

- Full blocking capability over wide temperature range
- High Surge current capability
- Hermetic metal case with ceramic insulator

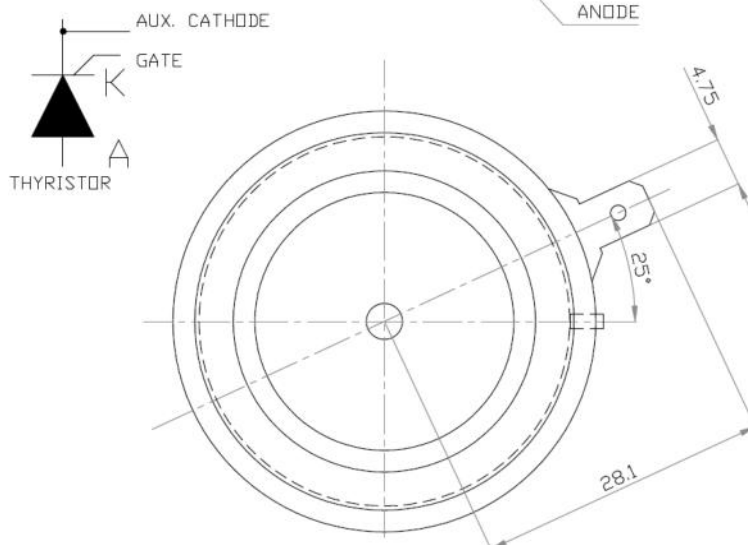
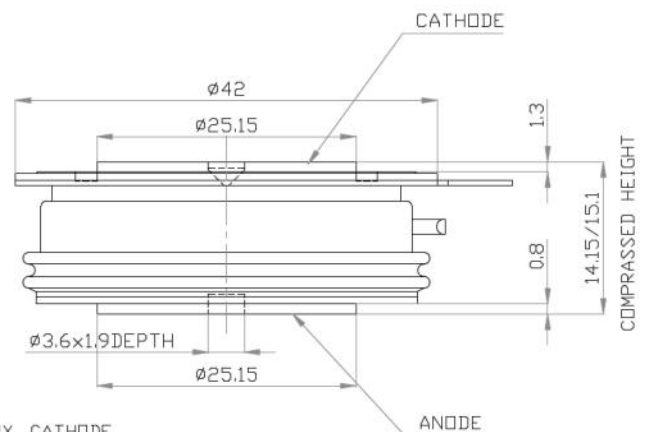

#### Applications

- Battery Chargers
- Medical Equipment
- UPS
- Power Supplies
- Motor control
- Controlled Rectifiers
- Transportation
- Induction Heating
- Welding

Symbol	Characteristic	Conditions	T <sub>j</sub> [°C]	Value	Unit
<b>BLOCKING</b>					
V <sub>RRM</sub>	Repetitive peak reverse voltage		125	200 - 600	V
V <sub>RSM</sub>	Non-repetitive peak reverse voltage		125	300 - 700	V
V <sub>DRM</sub>	Repetitive peak off-state voltage		125	200 - 600	V
I <sub>RRM</sub>	Repetitive peak reverse current	V = V <sub>RRM</sub>	125	50	mA
I <sub>DRM</sub>	Repetitive peak off-state current	V = V <sub>DRM</sub>	125	50	mA
<b>CONDUCTING</b>					
I <sub>T(AV)</sub>	Mean on state current	180° sin ,50 Hz, T <sub>c</sub> =70°C, Double side cooled 180° sin ,50 Hz, T <sub>c</sub> =83°C, Double side cooled		1155 960	A
I <sub>RMS</sub>	RMS on-state current			1813	A
I <sub>TSM</sub>	Surge on-state current	Sine wave, 10 ms Without reverse voltage	25	16000	A
			125	15000	A
I <sup>2</sup> t	I <sup>2</sup> t	Sine wave, 10 ms Without reverse voltage	25	1280 x 10 <sup>3</sup>	A <sup>2</sup> s
			125	1125 x 10 <sup>3</sup>	A <sup>2</sup> s
V <sub>T</sub>	On-state voltage	On-state current = 3000A	125	1.60	V
V <sub>T(TO)</sub>	Threshold voltage		125	0.85	V
r <sub>T</sub>	On-state slope resistance		125	0.25	mΩ
<b>SWITCHING</b>					
di/dt	Critical rate of rise of on-state current		125	150	A/μs
dv/dt	Critical rate of rise of off-state voltage	V <sub>DR</sub> = 67%V <sub>DRM</sub>	125	1000	V/μs
<b>GATE</b>					
I <sub>gt</sub>	Gate trigger current	V <sub>D</sub> =6V	25	150	mA
V <sub>gt</sub>	Gate trigger voltage	V <sub>D</sub> =6V	25	3.0	V
I <sub>H</sub>	Holding current	V <sub>D</sub> =6V, gate open circuit	25	300	mA
I <sub>L</sub>	Latching current	V <sub>D</sub> =6V	25	600	mA
<b>MOUNTING</b>					
R <sub>th(j-c)</sub>	Thermal impedance, sin 180°	Junction to case, Double side cooled		0.030	°C/W
R <sub>th(j-c)</sub>	Thermal impedance, rec120°	Junction to case, Double side cooled		0.034	°C/W
R <sub>th(c-h)</sub>	Thermal impedance	Case to heatsink, Double side cooled		0.01	°C/W
T <sub>j</sub>	Max. junction temperature			125	°C
T <sub>stg</sub>	Storage temperature			-40 .... 125	°C
M	Clamping Force			8	kN
W	Weight (Approx.)			85	gm

**DISSIPATION CHARACTERISTICS**

SINE WAVE

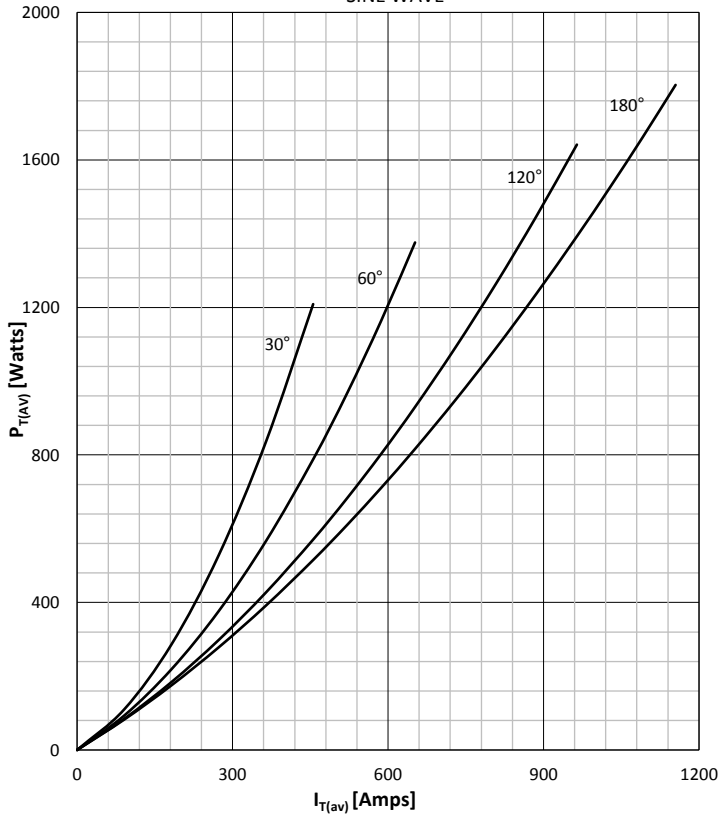
**ON STATE CURRENT DERATING CURVE**

SINE WAVE

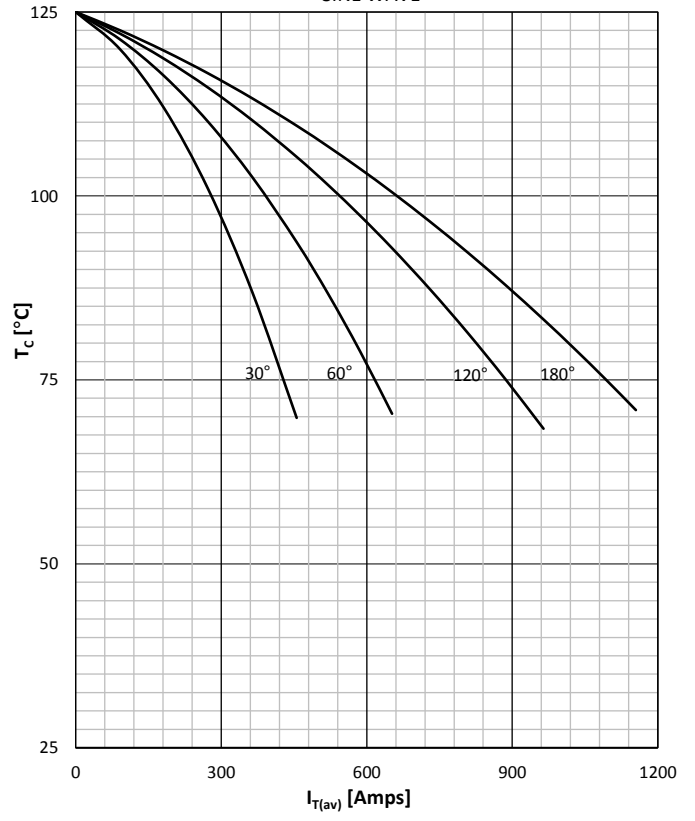
**DISSIPATION CHARACTERISTICS**

SQUARE WAVE

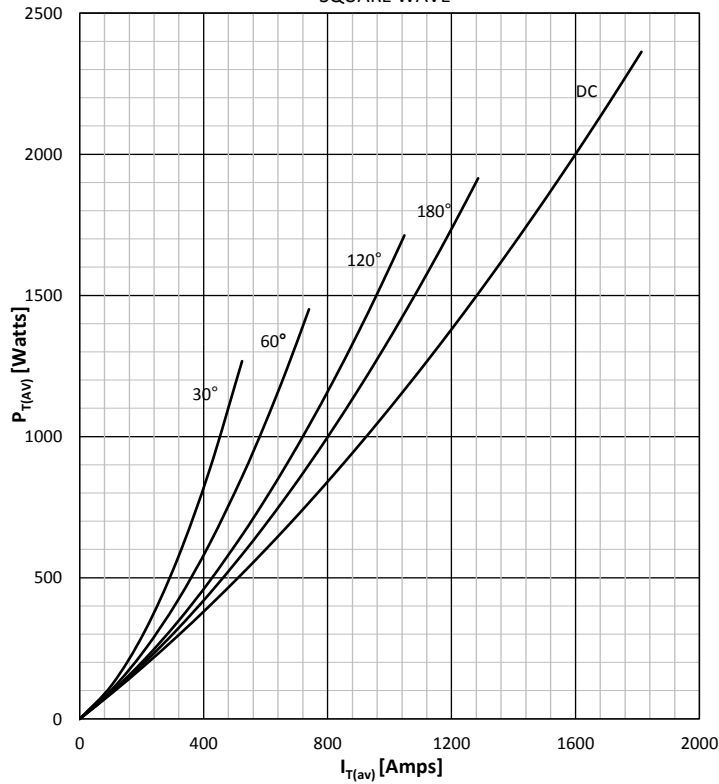
**ON STATE CURRENT DERATING CURVE**

SQUARE WAVE

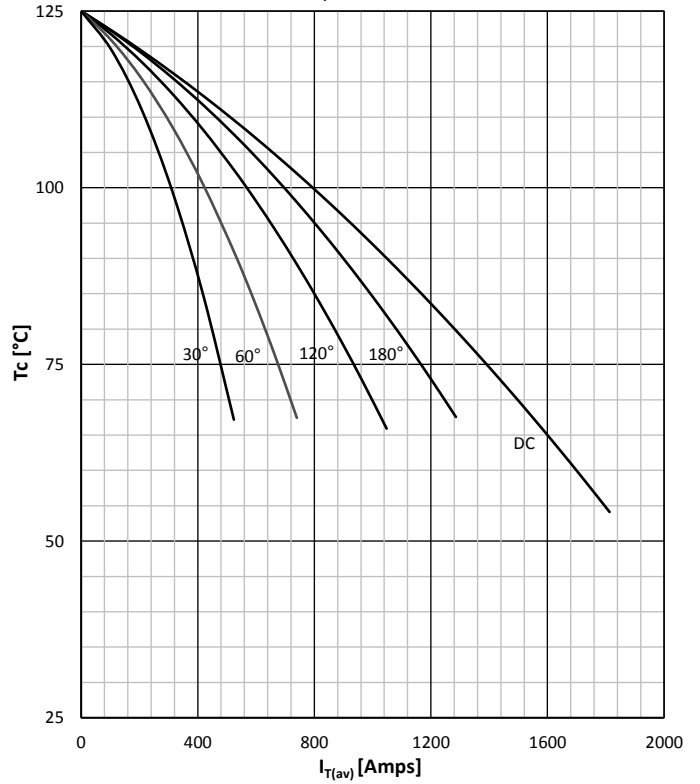

ON STATE CHARACTERISTIC

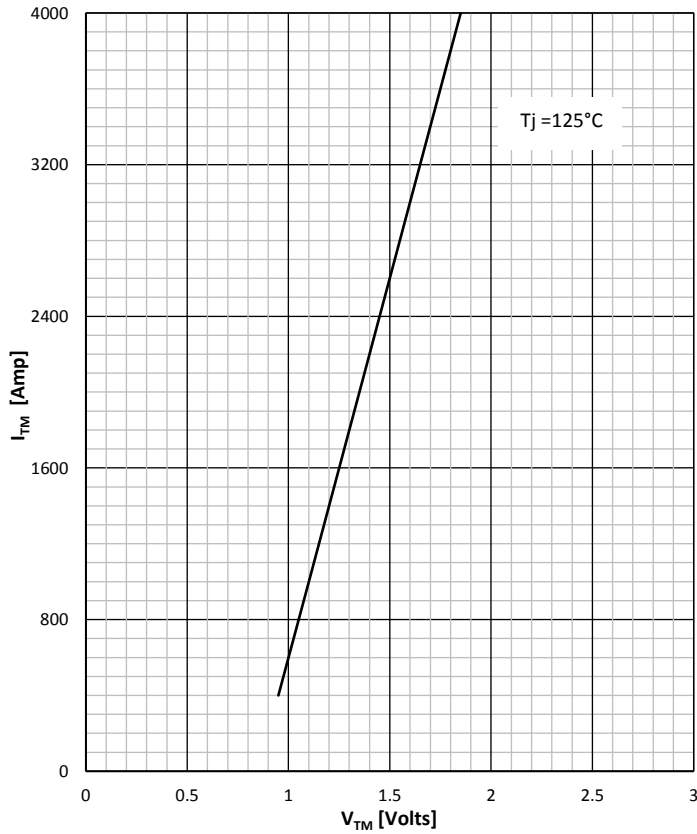

SURGE CHARACTERISTICS

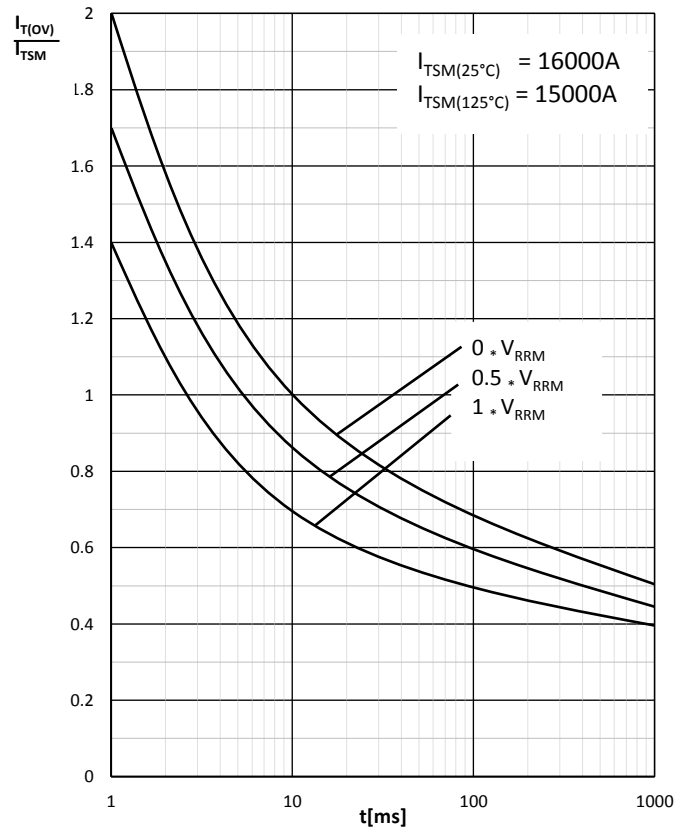

TRANSIENT THERMAL IMPEDANCE

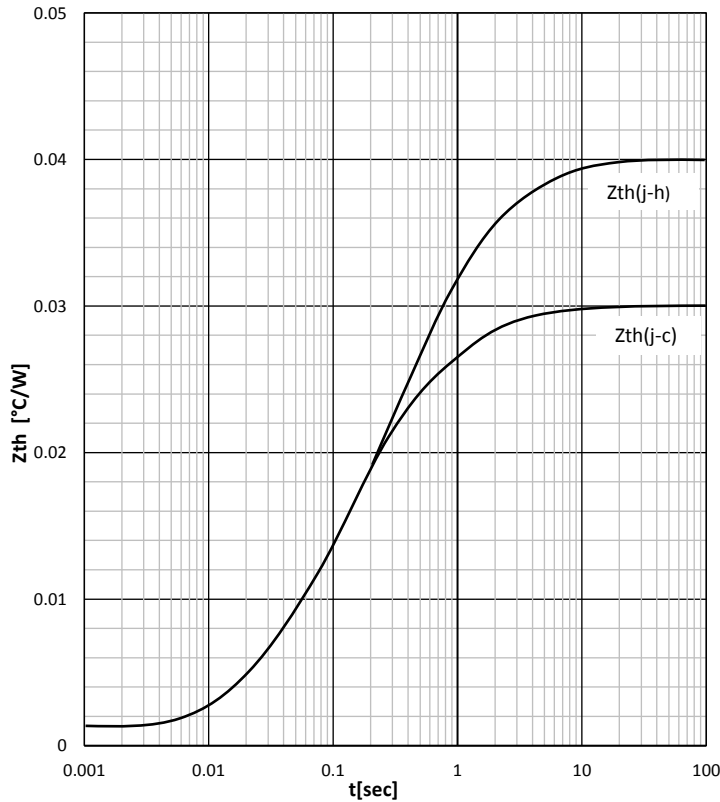

GATE TRIGGER CHARACTERISTICS

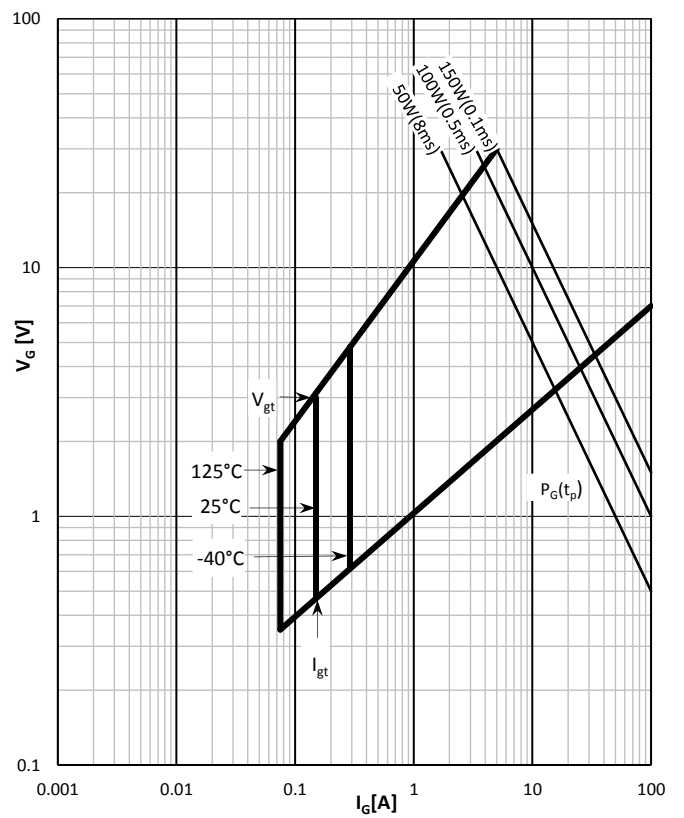

Scomes srl reserves the right to change any specification without notice

issue:sep-2020