

SCT1715

Power Rectifier Thyristor



Key Parameters

V_{DRM} / V_{RRM}	= 2800V
$I_{T(AV)}$	= 1715A
I_{TSM}	= 31kA
$V_{T(TO)}$	= 0.97V
r_T	= 0.27m Ω

Features

- Full blocking capability over wide temperature range
- High Surge current capability
- Hermetic metal case with ceramic insulator

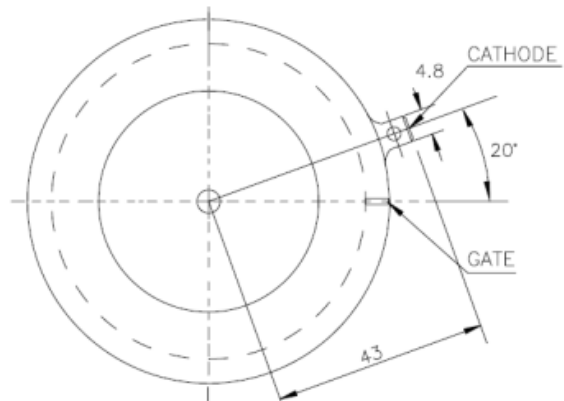
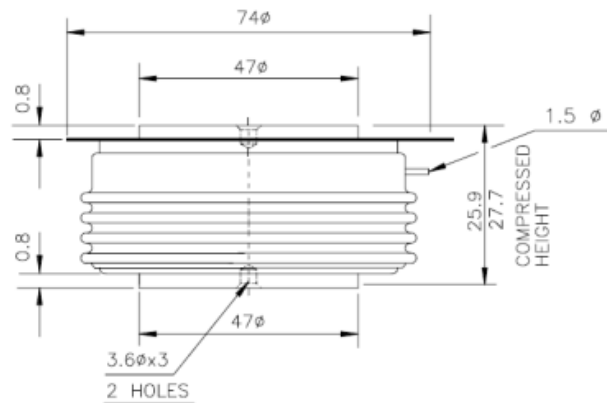

Applications

- Battery Chargers
- Medical Equipment
- UPS
- Power Supplies
- Motor control
- Controlled Rectifiers
- Transportation
- Induction Heating
- Welding

Symbol	Characteristic	Conditions	T _j [°C]	Value	Unit
BLOCKING					
V _{RRM}	Repetitive peak reverse voltage		125	2000 - 2800	V
V _{RSM}	Non-repetitive peak reverse voltage		125	2100 - 2900	V
V _{DRM}	Repetitive peak off-state voltage		125	2000 - 2800	V
I _{RRM}	Repetitive peak reverse current	V = V _{RRM}	125	70	mA
I _{DRM}	Repetitive peak off-state current	V = V _{DRM}	125	70	mA
CONDUCTING					
I _{T(AV)}	Mean on state current	180° sin ,50 Hz, T _c =70°C, Double side cooled 180° sin ,50 Hz, T _c =82°C, Double side cooled		1715 1460	A
I _{RMS}	RMS on-state current	T _c =70°C, Double side cooled		2692	A
I _{TSM}	Surge on-state current	Sine wave, 10 ms Without reverse voltage	25	31000	A
			125	30000	A
I ² t	I ² t	Sine wave, 10 ms Without reverse voltage	25	4805 x 10 ³	A ² s
			125	4500 x 10 ³	A ² s
V _T	On-state voltage	On-state current = 3000A	125	2.00	V
V _{T(TO)}	Threshold voltage		125	0.97	V
r _T	On-state slope resistance		125	0.27	mΩ
SWITCHING					
di/dt	Critical rate of rise of on-state current		125	200	A/μs
dv/dt	Critical rate of rise of off-state voltage	V _{DR} = 67%V _{DRM}	125	1000	V/μs
GATE					
I _{gt}	Gate trigger current	V _D =6V	25	250	mA
V _{gt}	Gate trigger voltage	V _D =6V	25	3.0	V
I _H	Holding current	V _D =6V, gate open circuit	25	600	mA
I _L	Latching current	V _D =6V	25	1000	mA
MOUNTING					
R _{th(j-c)}	Thermal impedance, sin 180°	Junction to case, Double side cooled		0.015	°C/W
R _{th(j-c)}	Thermal impedance, rec120°	Junction to case, Double side cooled		0.01725	°C/W
R _{th(c-h)}	Thermal impedance	Case to heatsink, Double side cooled		0.005	°C/W
T _j	Max. junction temperature			125	°C
T _{stg}	Storage temperature			-40 125	°C
M	Clamping Force			20 - 24	kN
W	Weight (Approx.)			500	gm

DISSIPATION CHARACTERISTICS

SINE WAVE

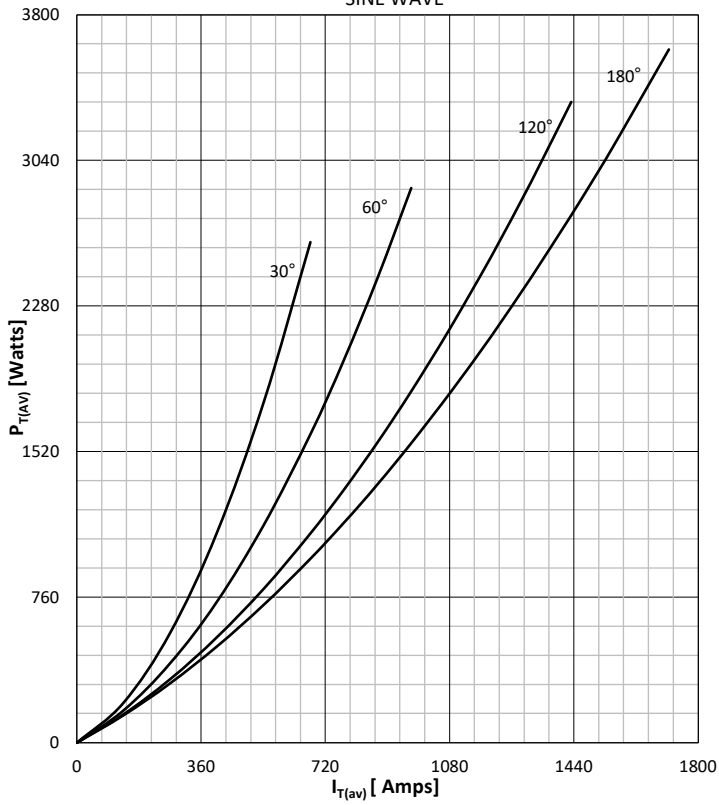
ON STATE CURRENT DERATING CURVE

SINE WAVE

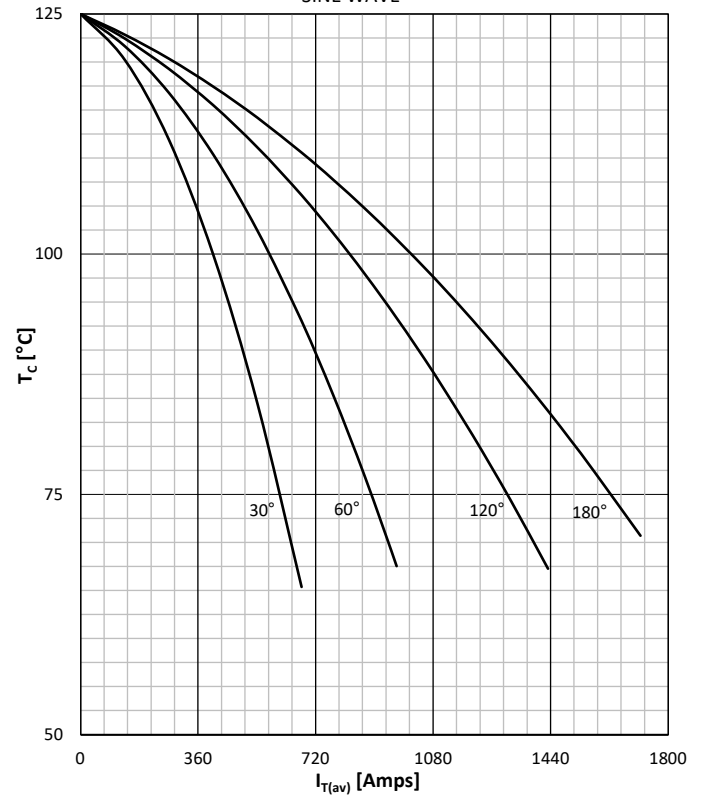
DISSIPATION CHARACTERISTICS

SQUARE WAVE

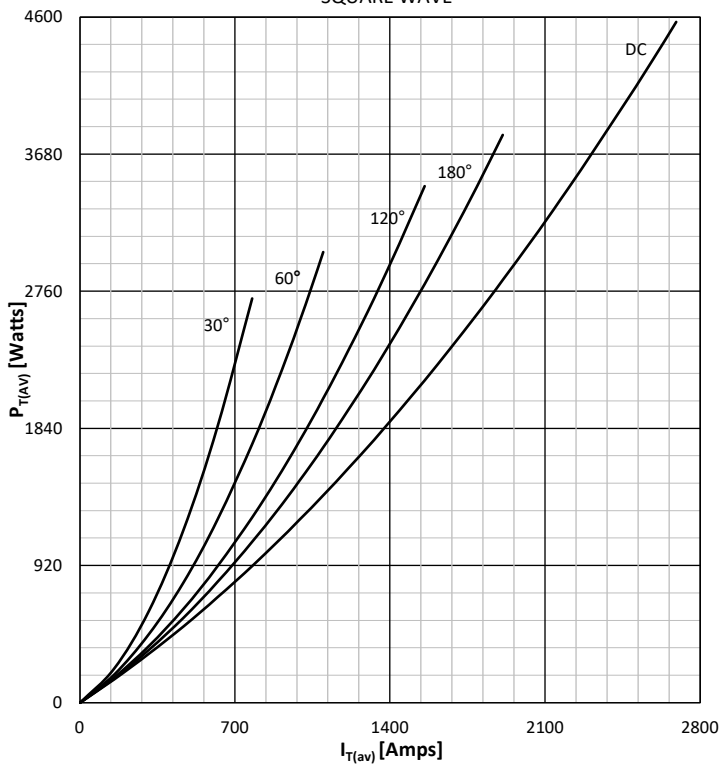
ON STATE CURRENT DERATING CURVE

SQUARE WAVE

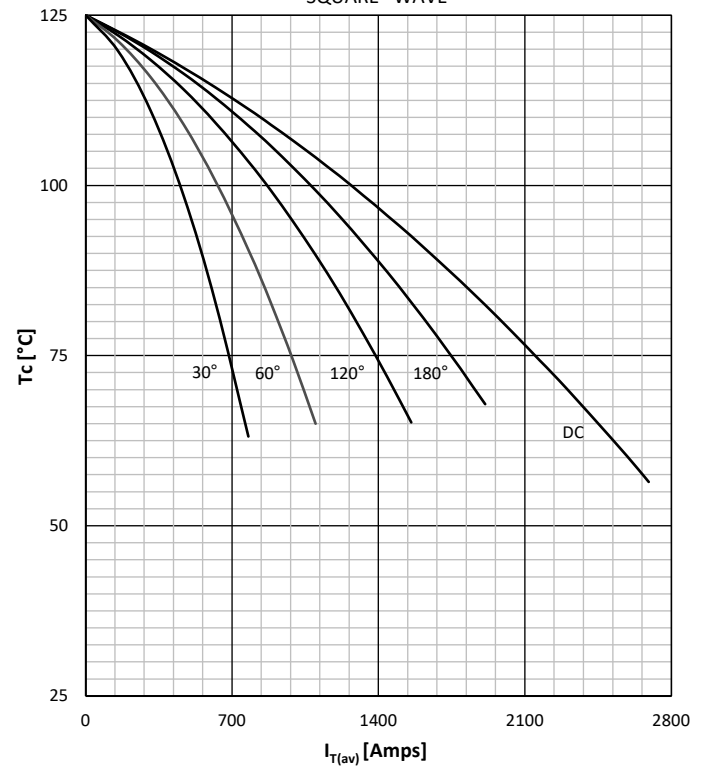

ON -STATE CHARACTERISTIC

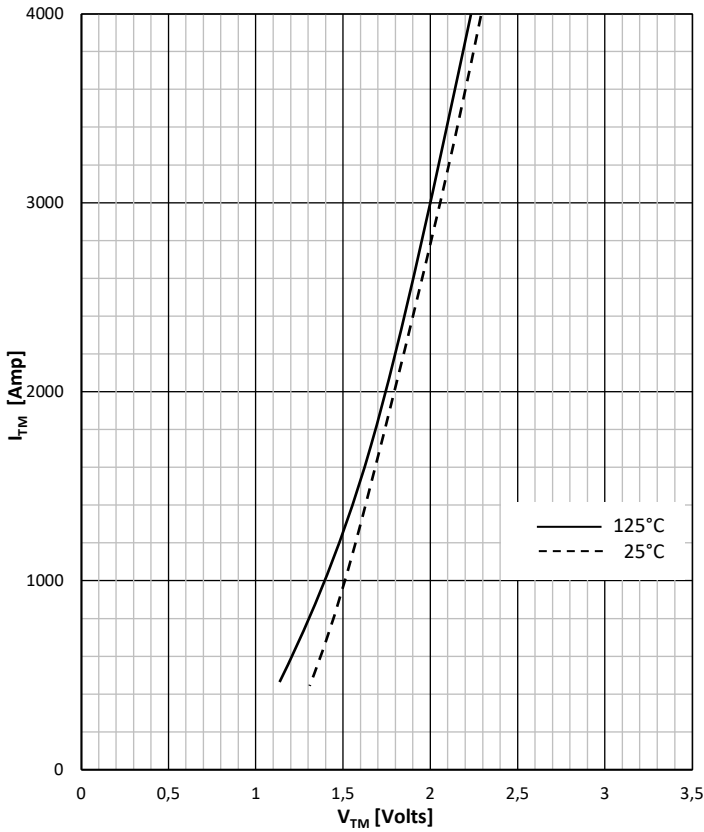

SURGE CHARACTERISTICS

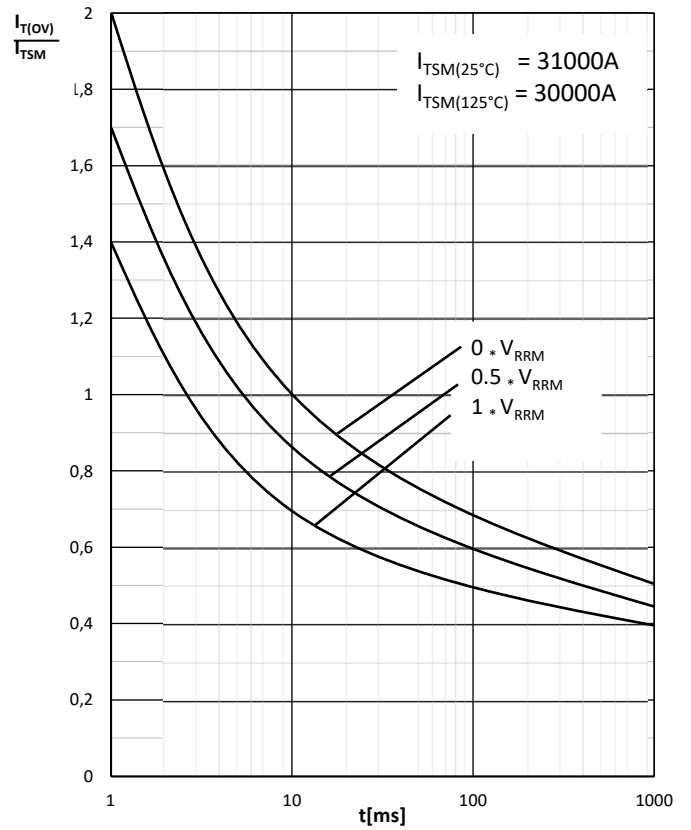

TRANSIENT THERMAL IMPEDANCE, PER ARM

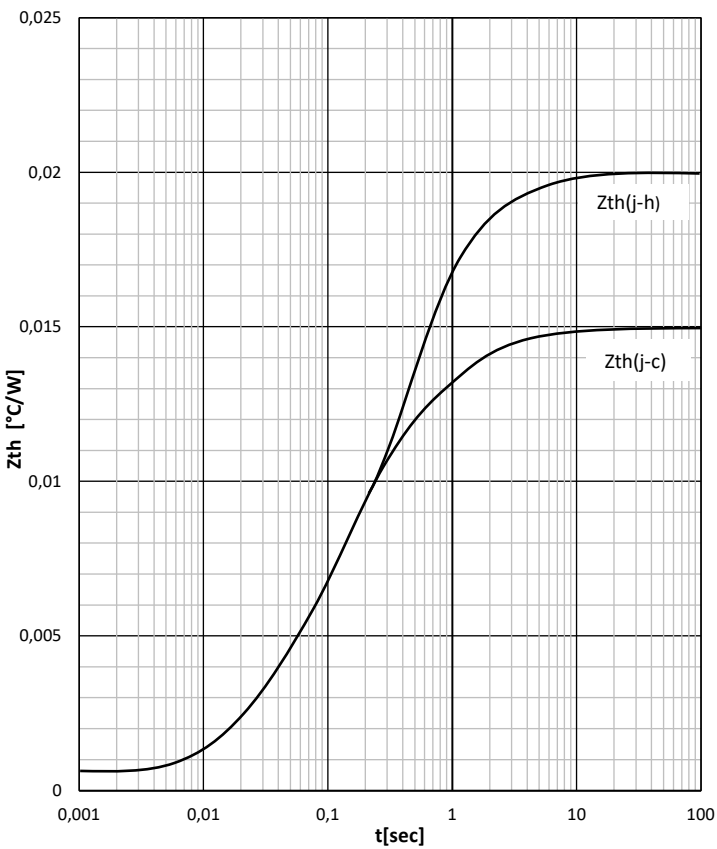

GATE TRIGGER CHARACTERISTICS

